



POWER PARAMETERS

Generating Rates

PRIME POWER		COP POWER	
1875 kva	1500 kW	1875 kva	1500 kW
	172 A		172 A
Voltage		6.3kV	
Rated at power factor Cos Ø		0,8	



Standby Rating (ESP)

According to ISO 8528-1:2018, Emergency standby power is the maximum power available during a variable electrical power sequence, under the stated operating conditions, for which a generating set is capable of delivering in the event of a utility power outage or under test conditions for up to 200h of operation per year with the maintenance intervals and procedures being carried out as prescribed by the manufacturers. The permissible average power output over 24h of operation shall not exceed 70% of the ESP. Overload is not allowed.

Standby power: According to the standard, the nominal power assigned by the genset is given for 25°C Air Inlet Temperature, of a barometric pressure of 100kPA (100 m A.S.L), and 30% relative humidity.

Prime Rating (PRP)

According to ISO 8528-1:2018, Prime power is the maximum power which a generating set is capable of delivering continuously whilst supplying a variable electrical load when operated for an unlimited number of hours per year under the agreed operating conditions with the maintenance intervals and procedures being carried out as prescribed by the manufacturer. The permissible average power output over 24h of operation shall not exceed 70% of the PRP. 10% overload capability is available for a period of 1 hour within 12-hour period of operation.

Dimensions / Weight / Fuel tank



	Dimensions W x L x H (mm)	Weight (kg)	Tank Capacity (lt)
Canopy	4000 x 14000 x 10260	TBA	n/a
Open Type	-	-	n/a

note:
Dimensions and weight are for reference only, do not use for installation design.
Please contact your dealer for exact weight and dimensions.

CHP ENCLOSURE NOISE LEVEL db(A)

1mt@<70 db(A)

TBA: To be asked, N/A: Not applicable
Technical data correspond to the available information at the moment of printing.

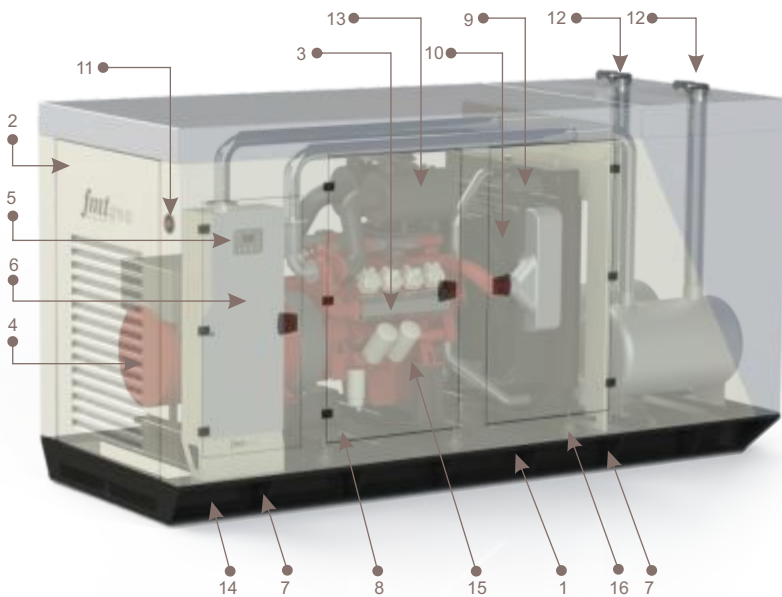

Low fuel consumption



High efficiency



Easy lift



Low noise

1	Base Frame	9	Radiator
2	Canopy	10	Cooling fan
3	Engine	11	Emergency stop button
4	Alternator	12	Exhaust Outlet
5	Control Panel	13	Air Filter
6	Connection Box	14	Earthing Point
7	Lifting Lug	15	Oil Filter
8	Battery	16	Vibration Isolators

**Image for guidance purposes*



FEATURES

- Galvanized steel that provides extra strength, durability and protection
- Tightly structure, excellent design
- Easy access to serviceable parts
- Double swinging doors for ease of service
- Doors have high quality gaskets to avoid leakage of sound
- LCD display shows system status and setup information
- Adequate ventilation to meet air requirement for combustion and heat removal



GENSET STANDARD SPECIFICATION

- Gas engine
- Water cooled
- Radiator with mechanical fan
- ATS automatic transfer switch 4P
- Protective grille for rotating and hot parts
- Electric starter and charge alternator
- Engine coolant heater
- Base frame with integrated fuel tank
- Engine oil filled
- Output circuit breaker 4P
- Anti-vibration shock absorbers
- Rubber fuel connection hoses
- Single bearing, class H alternator
- Industrial exhaust silencer and steel bellows supplied separately
- Static battery charger
- Starting battery (with lead acid) including rack and cables
- Battery isolator
- Manual for application and installation
- Jacket water heater

SAFETY FEATURES



HIGH WATER TEMPERATURE



PROTECTIVE EARTH POINT



LOW LUBE OIL PRESSURE



EMERGENCY STOP PUSH-BUTTON

TY..! 1 YEAR WARRANTY..! 1 YEAR WARRANTY..! 1 YE

1. Engine technical parameter list

ITEM	UNIT	VALUE
Model		RH4-16V80-GAS
Rated power	kW	1600
Quantity of Cylinders	PCS	16
Cylinder bore	mm	170
Stroke	mm	215
Displacement	L	78.04
Speed	rpm	1500
Compression ratio		12:1
Mean effective pressure	MPa	1.64
Mean speed of piston	m/s	10.75
Oil quantity	L	280
Cooling water quantity	L	180
Dimension(L*W*H)	mm	3495×1600×2400
Dry weight	kg	7880
Weight with oil	kg	8300
Moment of inertia of an area (flywheel)	kgm ²	11.35
Direction of rotation		CCW (Look at the flywheel)
Fly wheel		SAE21
EMC		N
Starter	kW	2×13 @DC24V

2. Heat balance list of generator set

ITEM	UNIT	VALUE
Electrical power	kW	1500
Gas energy	kW	3651
Electrical efficiency	%	41.08
Exhaust thermal*	kW	833
Water thermal of cylinder liner	kW	872
Thermal efficiency	%	46.7
Total efficiency	%	87.78

*Exhaust gas cooled to 120 °C for natural gas.

- Note: All data of gas generator sets are measured under the test environment: Methane volume content ≥95%, Gas temperature 10-40°C, Gas humidity <60%, Negative pressure of air intake >-3kPa, Exhaust back pressure <5kPa, Absolute atmospheric pressure 101.32kPa, Environmental temperature 25°C, Relative humidity ≤30%, Altitude ≤1000m

3. Combustion air and exhaust data sheet for engine

ITEM	UNIT	VALUE
Exhaust temperature	°C	≤580
Max Exhaust temperature	°C	620
Exhaust flow (including H ₂ O)	kg/h	7495
Max Exhaust back pressure	kPa	2.5
Diameter of exhaust pipe		DN400
Combustion air flow	kg/h	7221
Max air pressure before air filter	kPa	2.5

4. Gas consumption data sheet

ITEM	UNIT	VALUE
Gas type		Natural gas
Gas Consumption	Nm ³ /h	417
CH ₄	%	≥80
Methane number (MN)	/	≥80
Gas valve group inlet pressure	kPa	30-50
Engine inlet gas pressure	kPa	6~10
Rate of gas pressure change	kPa/sec	1
Rate of change of heating value of gas	%/min	≤2
Gas intake pipe	mm	100
H ₂ S	mg/Nm ³	≤20
All of the sulfur	mg/Nm ³	≤200
Solidparticle	μm/m ³	≤5
	mg/m ³	≤30

5. Technical parameters of engine lubricating oil system

ITEM	UNIT	VALUE
Lubricating oil system volume	L	280
Max oil temperature	°C	95
Oil consumption rate	g/kWh	≤0.25

6. Technical parameters of engine cooling system

ITEM	UNIT	VALUE
High temperature part heat dissipation	kW	872
Low temperature part heat dissipation	kW	150
Flow of jacket water	m ³ /h	75
Flow of Intercooler water	m ³ /h	65
High temperature water I/O	°C	74 to 84
Low temperature water I/O	°C	43 to 45
Max. temperature of jacket water	°C	90
I/O pipe of jacket water	DN/PN	DN80/PN16
I/O pipe of intercooler water	DN/PN	DN65/PN16
High temperature water pressure	MPa	0.23
Low temperature water pressure	MPa	0.13

7. Engine emission data

ITEM	UNIT	VALUE
NOx (5%O2)	mg/Nm ³	≤500
CO (5%O2)	mg/Nm ³	≤1006
HC (5%O2)	mg/Nm ³	≤132.7
O ₂	%	8
λ		1.6

8. Torsional vibration calculation parameters

Power	RPM		Connecting Rod Length	Main Journal	Crank pin Journal	Allowed crankshaft force
1600 kW	1500 rpm		360 mm	170 mm	130 mm	55 MPa
Bore (d)	Stroke(s)	Stroke	Efficiency	Single-Cylinder Reciprocating Mass	Crank-Rod Ratio	Cylinder Arrangement Angle
170 mm	215 mm	4	89%	15.24 kg	0.2986	90°
Firing Order	A1-A7-B4-B6-A4-B8-A2-A8-B3-B5-A3-A5-B2-A6-B1-B7					

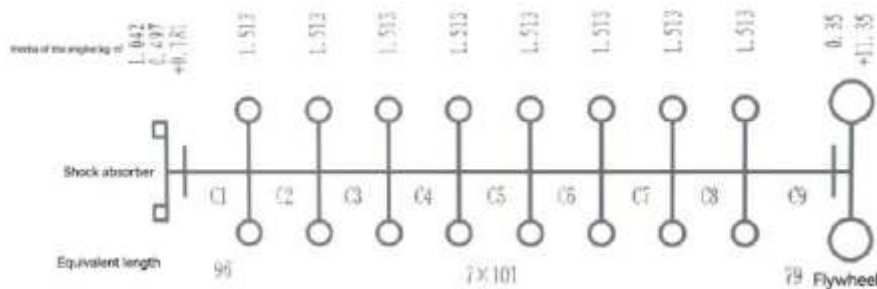

Torsional rigidity	C1	C2	C3	C4	C5	C6	C7	C8	C9
MNm/rad	10.4	7.952	7.952	7.952	7.952	7.952	7.952	7.952	11.49

9. Engine coolant

When choosing water as cooling medium, the following requirements should be met:

- A. Use clean water that is slightly alkaline and does not contain corrosive compounds
- B. The hardness is 0.7-5.3 mol/L, the content of chloride ion is less than 150mg/ L, and the PH value is 6.0-8.5
- C. If the water quality does not meet the above requirements, the corresponding softening water equipment or descaling equipment should be added according to the coefficient of 1.2 times of the consumption of cooling water.

Other cooling medium

When the ambient temperature is below 5°C, antifreeze should be selected as the cooling medium. When selecting antifreeze, the freezing point should be 5°C lower than the lowest temperature in the use area.

CHP Heat Recovery System

The cogeneration unit includes a complete heat recovery system consisting of plate heat exchangers, circulating pumps, and insulated hot-water piping.

Exhaust gas is cooled to ≤ 120 °C through the integrated exhaust heat exchanger.

A three-way bypass valve ensures stable operation under varying heat demand conditions.

An auxiliary emergency radiator allows continuous engine operation when no heat absorption is available.

Standards and Certifications: The cogeneration unit is manufactured under a certified quality system ISO 9001:2015 (Cert.No: 102026168, Certificate Validity Date: 01.11.2026) and complies with DSTU EN 60204-1:2015, DSTU-N IEC Guide 111:2007 (IEC Guide 111:2004, IDT), the Low Voltage Directive 2014/35/EU, and the EMC Directive 2014/30/EU.

Engine Control System

The RH4-16V80-GAS engine uses HEINZMANN control system from Germany, The HEINZMANN gas engine control system is renowned for its high-precision control and reliability, its key advantages include:

1. Precise Air-Fuel Ratio Control
 - Utilizes a closed-loop control system that continuously monitors oxygen levels and gas flow to achieve optimal air-fuel ratio adjustment, enhancing combustion efficiency.
 - Reduces fuel consumption, lowering operational costs while optimizing emissions to meet environmental regulations.
2. Advanced Ignition and Combustion Optimization
 - Features an intelligent ignition control system that adjusts ignition timing based on load and operating conditions, improving combustion efficiency and reducing knocking risks.
 - Adapts to various gas qualities (e.g., natural gas, biogas, syngas), providing strong fuel flexibility.
3. High Integration and Intelligent Management
 - The control system integrates electronic speed control, ignition management, air-fuel mixing, and emissions control, minimizing dependency on external controllers and enhancing reliability.
 - Equipped with remote monitoring and data logging functions, enabling real-time tracking of engine performance for easier diagnostics and maintenance.
4. Fast Dynamic Load Response
 - Uses high-speed electronic actuators to quickly adjust gas supply, ensuring smooth load transitions, which is especially beneficial for grid-connected power generation or fluctuating load applications.
5. High Reliability and Durability
 - Designed with industrial-grade hardware, offering high resistance to interference and suitability for harsh environments (e.g., high temperatures, humidity, and vibrations).
 - Long service life with low maintenance costs, making it ideal for continuous-duty generator sets.
6. Compliance with International Emission Standards
 - Through precise combustion control and optimization, HEINZMANN systems significantly reduce NOx, CO, and unburned hydrocarbons (HC) emissions, meeting strict EU Stage V and EPA Tier 4 emission standards.

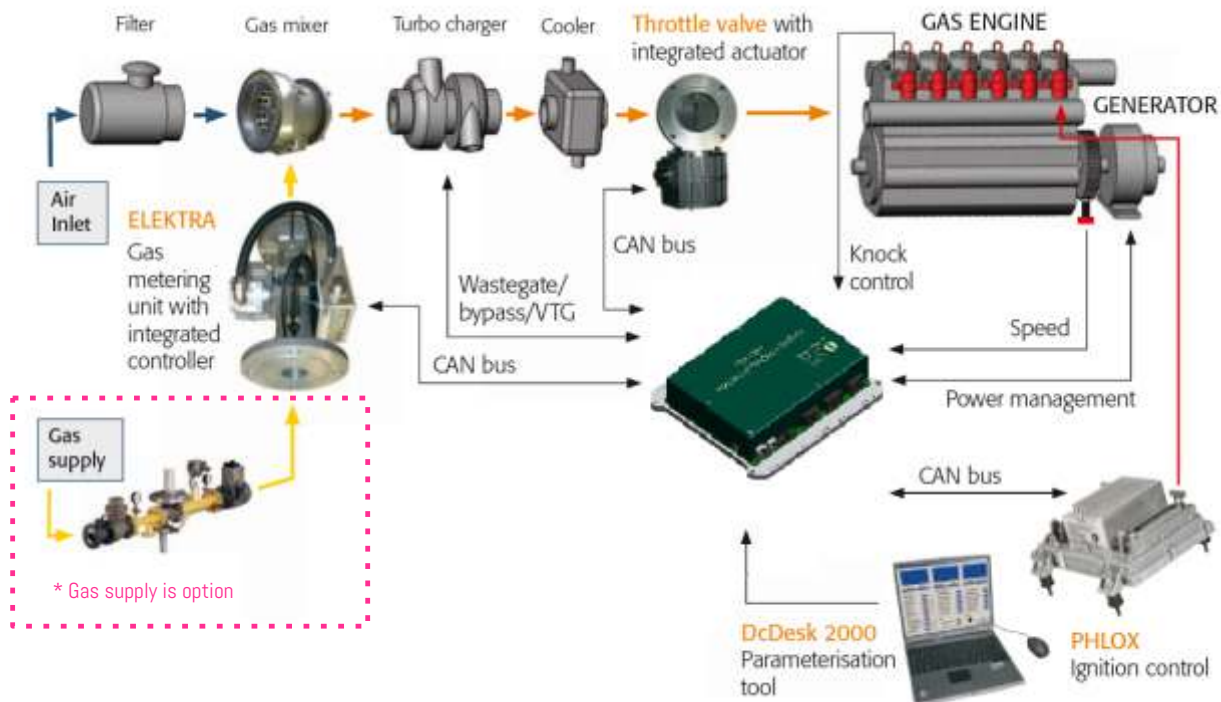

Engine Main Parts

Engine Main Parts	Discription
<p>Engine and block: nodular cast iron the tensile strength can reach 120kgf/m², and it has good toughness.</p>	<p>Engine body and cylinder head are made by nodular cast iron. Strong ability to bear mechanical load. Globular gold has less cracking effect on the metal matrix, It can make cast iron strength reach 70 ~ 90% of the matrix structure strength, the tensile strength can reach 120kgf/m² and it has good toughness.</p>
<p>Moving Parts: 42CrMoA alloy steel. Enhance the life of moving parts reach 100,000 hours.</p>	<p>Crankshaft, camshaft and other moving parts are made of 42CrMoA alloy steel. It has a higher fatigue limit and resistance to multiple impacts after treatment, good impact toughness and outstanding wear resistance. Will adopt whole forging to retain the internal natural state of the metal, greatly improves the crankshaft strength, and enhances the crankshaft wear resistance used special heat treatment. This crankshaft will be increased more than 20% strength, enhance the life of moving parts reach 100,000 hours.</p>
<p>Inlet & exhaust valves valve seats: MAERKISCHES WERK GMBH</p>	<p>Regenerate Gas Engine used original imported German inlet & exhaust valves and valve seats (MAERKISCHES WERK GMBH). The service life of inlet & exhaust valves and valve seats of Regenerate Gas Engine are much longer than similar domestic products. The patented rotary air valve technology is used in fitting between the intake & exhaust valve with their valve seats. Valves and valve seat are continuously grinding during the operation of engines, let sealing surface between the two always fitted, it will double extend valves life time and rejecting "pre-ignition" and "post-ignition" of the gas engines.</p>
<p>Turbo-chargers</p>	<p>RH4-16V80-GAS gas engine is equipped with two original imported ABB TPS series Turbo-chargers to provide strong power for the engine.</p>

Generator Set Control Cabinet

The generator set control panel is easy to operate, featuring one-touch start/stop, one-touch synchronization, and one-touch circuit breaker operation, along with an emergency stop function.

For containerized generator sets, the control panel is located inside the control room of the container.

The main controller of the generator set is the DEIF150E with Heinzmann MHI system, which supports synchronization and parallel operation.

We integrated the DEIF150E generator set master controller and all control modules of the Heinzmann gas engine control system in a single control panel, displayed on the same HMI

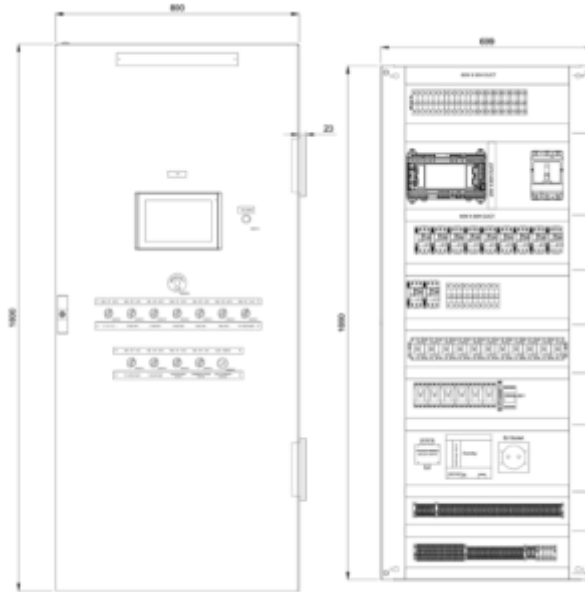

Gas Transmission System

Gas system (NGL) includes pressure reducing valves, solenoid shut-off valves, manual shut-off valves, filters and other equipment, which are installed inside into the container. The main valves of the gas transmission system adopt original German DUNGS products, DUNGS has Vibration tested combination controls Multi block and Gas Bloc according US Military Standard MIL-STD-810G/31. Worldwide support via DUNGS branches and subsidiaries in more than 50 countries.

* Flame arrester is opinion

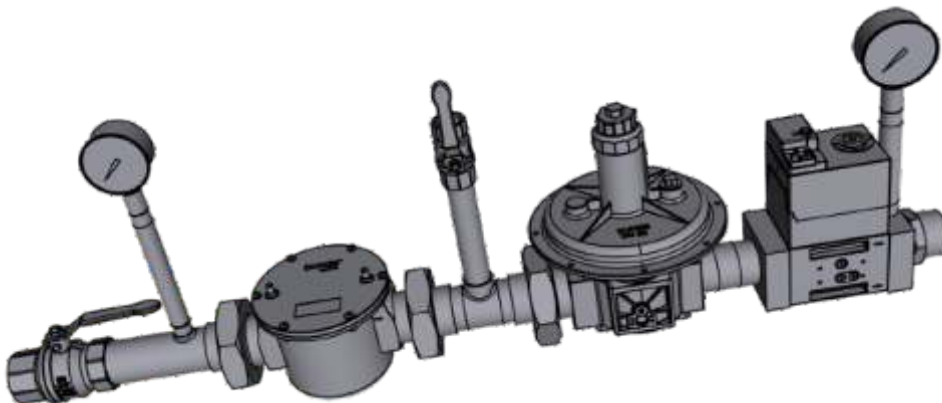

Cooling System

Including a horizontal type radiator and a set of cooling equipment.

- Cooling skid-mounted mainly include shut-off valves, high-temperature water pumps, low-temperature water pumps, plate heat exchanger, synchronous control and power management system, electric three-way ball valves, cooling water preheating devices and related instruments.
- The cooling fans are equipped with automatic controllers, will turn on/off the numbers of fans according to the temperature.



Silent Container And Exhaust System

- Container structure:

Container basic is detachable, whole assembled and ensure the strength and rigidity of the container after installing all the main and auxiliary equipment, can be hoisted without any deformation.

The installation position of the exhaust air door is flush with the top of the container, preventing any "dead zone".

The railing at the top of the container forms complete protection.

Should reserve door or passageway near generator set (Air inlet side) for maintenance.

- * Base: Designed welded with Channel steel for thick insulation, keep Container inside warmly in extreme cold weather.

- Two levels of alarm for gas leak.

First level (Alarm): 0.5% VOL. Alarm and turn on all fans for ventilating.

Second level (Danger): 1% VOL. Alarm, turning on all fans for ventilating and close gas solenoid valve to stop the running of gas generator set.

- Exhaust system (Standard):

Including exhaust muffler, exhaust pipes, insulation materials, and mounting / support hardware. Exhaust muffler should adopt industrial-grade, fire-extinguishing muffler, capacity of muffler not less than 25dB (A), equipped with a condensate drainage device.

SELF EXCITED STRONG ROTOR

Isolated Stator

Alternator has been designed for three phase and mono phase. They are brushless type and are controlled by AVR card. The windings have been industrially produced to give maximum efficiency in the production of energy. Throughout the AVR card system the output voltage is always stable. The smart AVR is a professional controller than enables the whole operation of excitement. Alternator is protected by a special cabin that enables the electrical connections.

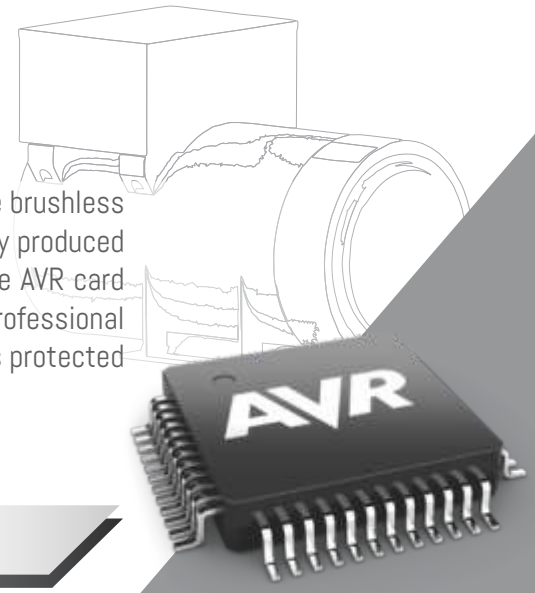

ALTERNATOR SPECIFICATION



GENERAL DATA

Model	PO2000-MV
No. of Phase	3
Power Factor	0.8
No of Bearing	SINGLE
No of Poles	4
No of Leads	6
Insulations Class	H
Voltage Regulation (Steady State)	± 0.5%
Degree of Protection	IP 23
Excitation System	Self excited, AVR, Brushless
Connection System	STAR
Frequency	50 Hz
Voltage Output	6.3kV

The alternator is rated at $\cos \Phi = 0.8$ and is suitable for continuous operation in the power factor range 1.0 to 0.90 lagging in grid-parallel mode.

Alternator Structure

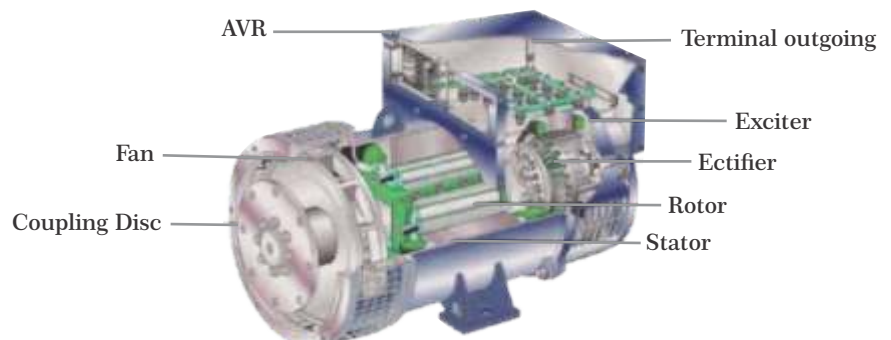

Ambient Temperature	40°C	Excitation	Brushless	Short Circuit Current Capacity (with PMG)	≥300%
Temperature Rise	105K	Winding Pitch	5 / 6	Method of Cooling	IC01
Service Duty	Continuous	Power Factor	0.8	Direction of Rotation	CW
Phase	3	Insulation Class	Class H	Maximum Over-speed	1800 rpm
Pole	4	Waveform : TIF	<50	Degree of Protection	IP23
Voltage Regulation Accuracy	+/- 0.5%	Waveform : THF	<2%	Radio interference	Class B Group I
AVR Model	PO-MV/2000	Altitude	≤1000 m.a.s.l	Total Harmonic Content	< 2% - At no load

Electrical and Mechanical Characteristic

Frequency	Hz	50
Round per minute	rpm	1500
Voltage (Y Connection) - Star	V	6300
Rated power at Class F (105K) temperature rise	kVA	1875.0
	kW	1500
Rated current	A	171.8
Efficiency at Class H (P.F.=0.8)	100%	96.0
	75%	96.0
	50%	95.3
Efficiency at Class H (P.F.=1.0)	100%	97.0
	75%	97.0
	50%	96.2

Short-circuit ratio	Kcc	0.5700
Direct axis synchronous reactance unsaturated	Xd	1.7681
Quadrature axis synchronous reactance unsaturated	Xq	1.1363
Direct axis transient reactance saturated	X'd	0.1434
Direct axis subtransient reactance saturated	X''d	0.1275
Quadrature axis subtransient reactance saturated	X''q	0.1406
Zero sequence reactance unsaturated	X0	0.0666
Leakage reactance	X _L	0.0900
Negative sequence reactance saturated	X2	0.1341

Open circuit time constant (sec.)	T'do	4.6330
Short-circuit transient time constant (sec.)	T'd	0.3370
Subtransient time constant (sec.)	T''d	0.0021
Armature time constant (sec.)	T _α	0.0365
No load excitation current	io(A)	1.5
Full load excitation current	ic(A)	3.8
Full load excitation voltage	uc(V)	59
Stator Winding Resistance (20°C)	ohm	0.2058
Rotor Winding Resistance (20°C)	ohm	0.7047
Exciter Stator Resistance (20°C)	ohm	10.84
Exciter Rotor Phase resistance	ohm	0.02194
Cooling air requirement	m ³ /sec	1.82

Configuration	Single Bearing	Double Bearing
Type of Construction	B2 - SAE	IM B20
Inertia (J) [kgm2]	66.1	65.8
Total Weight	4710	4728
Drive end bearing / Lubrication	Not supply	6328 C3 / With grease nipple
Non-drive end bearing / Lubrication	6328 C3 / With grease nipple	
Voltage Recovery Time - sec.	1.5	
Stator winding	DOUBLELAYERLAP	
Number of Terminal	6	
Rotor	with damping cage	
Overload	110% rated load for 1 hour	

GAS TRAIL SYSTEM

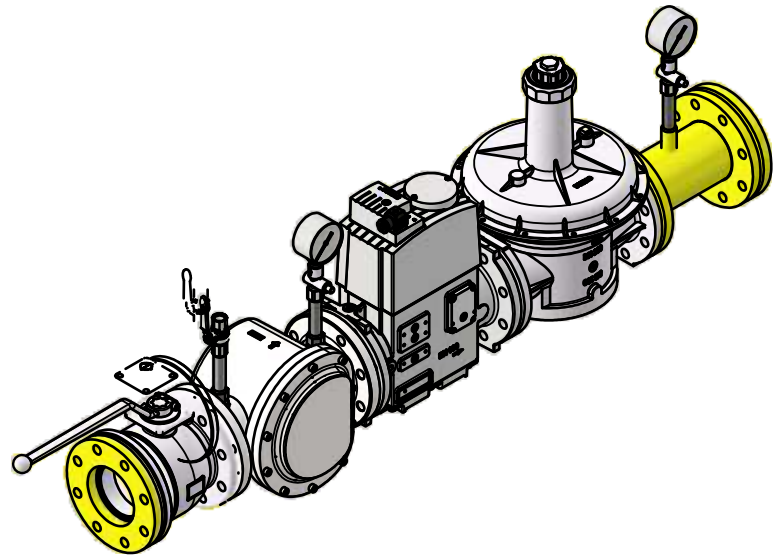
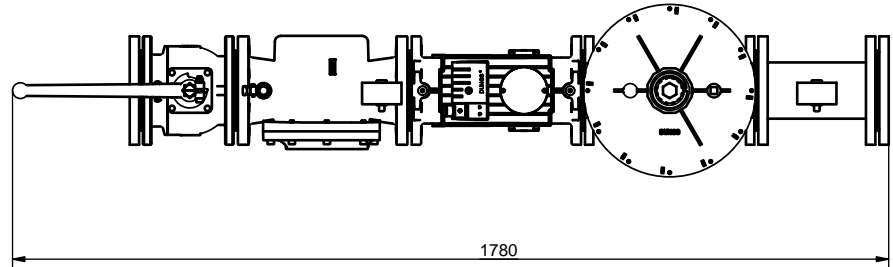
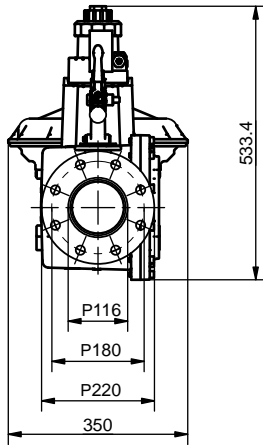
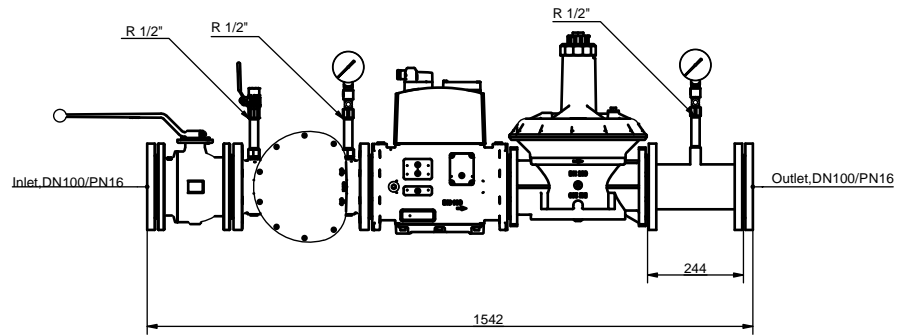
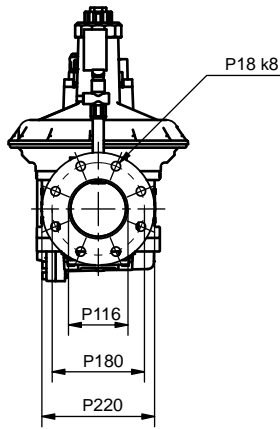

Medium:	Natural Gas
Gas flow:	
Min. inlet pressure:	150mbar
Max. inlet pressure:	350mbar
Max. operating pressure:	350mbar
Outlet pressure:	110mbar
Voltage:	24 VDC
El. degree of protection:	IP54
Flow direction: ◀ ▶	From left to right
Temperature:	-10-60°C
Pressure Equipment Directive:	

SYNCHRONIZE SYSTEM

SYNCHRONIZE CONTROL UNIT



SMART LOGIC / FULL PROTECTION

The AGC 150 Hybrid is a variant of the well-known and easy-to-use controller, AGC 150. The AGC 150 Hybrid comes with all the necessary functions for protection and control of a hybrid installation with PV and genset. It can be used as a single unit for PV and up to 2 gensets for synchronising projects, in island or parallel to the mains modes. The AGC 150 Hybrid handles the power production from PV and genset to give the highest PV penetration and the lowest CO2 emission, and to ensure safe power production to support the load. The AGC 150 Hybrid can be used as: • Hybrid controller mounted directly on the genset with full control of PV, genset and mains • PV integration controller with power measurement and breaker feedback from existing controller. The AGC 150 contains all necessary 3-phase measuring circuits. All values and alarms are presented on the sun proof LCD display.

STANDARD

DEIF150
3P5-V400-DEIF150

DOWNLOAD
datasheet



OPTIONAL



IntelliGen4 200
3P5-V400-CI200

DOWNLOAD
datasheet

IntelliGen4 200 is a diesel gen-set control unit for common paralleling applications supporting both single and multiple gen-sets running in grid-tied or island operations.



General description

The AGC 150 Hybrid is a variant of the well-known and easy-to-use controller, AGC 150. All technical information on this variant is found in the AGC 150 documentation on deif.com.

The AGC 150 Hybrid comes with all the necessary functions for protection and control of a hybrid installation with PV and genset. It can be used as a single unit for PV and up to 2 gensets for synchronising projects, in island or parallel to the mains modes.

The AGC 150 Hybrid handles the power production from PV and genset to give the highest PV penetration and the lowest CO emission, and to ensure safe power production to support the load.

The AGC 150 Hybrid can be used as:

- Hybrid controller mounted directly on the genset with full control of PV, genset and mains
- PV integration controller with power measurement and breaker feedback from existing controller.

The AGC 150 contains all necessary 3-phase measuring circuits. All values and alarms are presented on the sun proof LCD display.

Applications

The AGC 150 is a compact all-in-one unit designed for the following hybrid PV and genset applications:

Plant mode	Application
Island mode	Plant with PV inverters and synchronizing generators or a stand-alone generator.
Automatic Mains Failure	Plant with PV inverters, genset(s) and mains. Black start generator
Fixed power	Plant with fixed kW set point for PV inverters.
Peak shaving	Plant with PV inverters, where a generator supplies peak load demand paralleled to the mains.
Load take-over	Plant with PV inverters, where the rest load is moved from mains to generator.
Mains power export	Plant with fixed kW set points for PV inverters and mains.

Main hybrid features

Minimum genset load

- Eliminate the risk of reverse power caused by low load

Perfect for Rooftop installations

- Rebuild your genset with AGC 150 benefits and get PV for free

Load calculation in terms of solar power

Automatic genset start/stop

- Based on threshold set points for PV production and mains import/export

PV included in modes

- MPE (Mains power export/import), AMF (Automatic mains failure), LTO (Load take-over), Fixed power, and Peak shaving

PV inverter communication support

- Support of more PV inverter communication protocols, including Sunspec

Mains voltage and current measurement

- One CT/Phase for balanced load

PV Power emulation

- Try and test the Hybrid functions without a PV plant

Other PV features:

- Energy Counters, Curtailment
- Inverter monitoring
- POA and BOM for calculating P max
- Weather data presentation

Other features

Easy and user-friendly interface

- Adaptive mimic with easy switching between applications
- Only buttons relevant for a function are visible to the user

New design - Easy to mount

- Compact design making it suitable for all applications

Three user levels

- With configurable passwords for each parameter, only relevant parameters are shown

Shortcut menu

- Easy access to frequently used functions (configurable)

PLC functions

- Programmable and user-friendly functions (M-Logic)

Alarm and Event logging

- Up to 500 alarms and 500 events

Graphical Display

- Important information is shown on the easy-to-read display

Built-in analogue AVR and GOV control

- Eliminates the need for external equipment (voltage and PWM)

CIO support

- Support of CANbus based I/Os, increases the number of I/Os

Stage V and Tier 4 Final

- AGC 150 can be used with the latest electrical Tier 4 Final engines and show values requested by Stage V.

Function and features

Key functions and features

- PV power control
- PV active/reactive power counters
- Inverter monitoring
- Weather station support
- Engine start sequences
- Engine and generator protections
- Engine communication via CANbus
- Run coil and crank configurable when using electric engine
- Tier 4 Final support with clear alarm indications
- Diesel and gas genset support
- 3-phase generator and busbar sensing
- Phase compensation for D/Y transformer
- Four current sensing inputs
- Integrated governor and AVR outputs for control
- State-of-the-art synchronisation and load sharing
- Synchroscope and sync check
- Digital voltage regulation support for different DVR
- Voltage and frequency matching
- Three synchronisation methods: Dynamic, Static and Close before excitation
- 12 digital outputs (configurable)
- 12 digital inputs (configurable)
- Two analogue outputs (-10 to 10 V)
- Four multi-inputs:
 - Resistor, 0 to 4000
 - Voltage, 0 to 10 V
 - Current, 4 to 20 mA
 - Digital input
- Deadbus sensing
- Ground relay
- Mains support for stand-alone system (AMF)
- Analogue load sharing with external box
- ROCOF and Vector jump protection
- Fuel usage monitoring
- Maintenance alarms
- Grid support
- Ethernet interface as standard
- PV inverter communication (Modbus Master) on RS-485 port 2

Easy overview

- Remote monitoring support with Insight
- Weekly scheduler
- Emulation for testing and frontload commissioning
- Built-in Guided experience to help the user
- PV and engine alarms in clear text on the display
- Graphical display:
 - LCD, back-lit
 - High resolution, 240 x 120 pixels
 - Six lines
 - Operating temperature from -40 to +70 °C (-40 to +158 °F)
- Five-key navigation menu
- Event log with 500 entries (can be exported to a CSV file)
- Alarm log with 500 entries (can be exported to a CSV file)

Highly configurable

- Controller configuration from the front panel (PIN code protected) or with free PC tool via USB, Ethernet & RS485
- PC tool with trending and wizards helping the user with configuration
- 20 configurable display views
- Four fully configurable PID controllers
- CAN flags between controllers
- CANbus based extension module for Inputs/Outputs
- Real time clock
- User configurable logic (lite PLC)
- Ethernet communication for PLC, SCADA or BMS
- Multi-language support (incl. Chinese, Russian and other languages)

Four software packages

The AGC 150 can be equipped with four different software packages:

- **Stand-alone:** Non-sync application
- **Core:** Simple paralleling, like rental and constructions
- **Extended:** Standby power, like simple backup power stations
- **Premium:** Small CHP or similar medium complex sites

Note: The Hybrid functions are only supported by **Stand-alone Core** and **Extended** software packages.

See the data sheet for a more detailed description of each package.

Digital AVR support

Together with DEIF's DVC 310 or DVC 550 digital voltage controllers, the AGC 150 supports features such as Engine AID (for the rental market) and fast and secure CBE critical power start-up (run-up syncing).

Technical specifications

Power supply

- Nominal voltage: 12/24 V DC
- Operating range: 6.5 to 35 V DC
- Load dump protection (ISO16750-2)
- Measuring range: 0 to 50 V DC (35 V DC continuously)

Operating conditions

- Operating temperature: -40 to +70 °C (-40 to +158 °F)
- Storage temperature: -40 to +85 °C (-40 to +185 °F)

Environment

- Altitude: 0 to 4000 m
- Humidity: 20/55 °C at 95 % RH
- Protection degree: IP65 in panel, IP20 on terminals
- Pollution degree 2
- Self-extinguishing plastic

Measuring

- Voltage range: 100 to 690 V, phase-to-phase
- Max. measured voltage: 10 to 135 % of nominal
- Voltage accuracy: ±1 % of nominal
- Current range: 1 A and 5 A, 2 to 300 %
- Max. measured current: 3/15 A overload
- Current accuracy: ±1 % of nominal
- Frequency range: 3.5 to 75 Hz
- Power accuracy: ±1 % of nominal

Inputs/Outputs

- Digital inputs: 12 (max. +50 V, min. -24 V)
- Digital outputs: 2 (15 A inrush / 3 A continuously)
10 (2 A inrush / 0.5 A continuously)
- Digital common: 12/24 V DC
- Analogue inputs: 4
- Analogue outputs: 2
- CANbus 1 and 2
- RS-485 1 and 2 (PV inverter communication on 2)
- RJ-45 Ethernet
- USB (service-port)

Approvals

- CE
- cULus recognized to UL6200:2019, 1. ed. controls for stationary engine gensets

Protections

2 x Reverse power	ANSI 32R
2 x Short circuit	ANSI 50P
4 x Over-current	ANSI 51
1 x Voltage-dependent over-current	ANSI 51V
2 x Over-voltage	ANSI 59P
3 x Under-voltage	ANSI 27P
3 x Over-frequency	ANSI 81O
3 x Under-frequency	ANSI 81U
1 x Unbalanced voltage	ANSI 47
1 x Unbalanced current	ANSI 46
1 x Under-excitation or var import	ANSI 32RV
1 x Over-excitation or var import	ANSI 32FV
5 x Overload	ANSI 32F
1 x Earth current	ANSI 51G
1 x Neutral current	ANSI 51N
3 x Busbar/mains over-voltage	ANSI 59P
4 x Busbar/mains under-voltage	ANSI 27P
3 x Busbar/mains over-frequency	ANSI 81O
3 x Busbar/mains under-frequency	ANSI 81U
1 x Emergency stop	ANSI 1
2 x Overspeed	ANSI 12
1 x Low auxiliary supply	ANSI 27DC
1 x High auxiliary supply	ANSI 59DC
1 x Generator breaker external trip	ANSI 5
1 x Tie/mains breaker external trip	ANSI 5
Synchronisation failure alarms	ANSI 25
Breaker open failure	ANSI 52BF
Breaker close failure	ANSI 52BF
Breaker position failure	ANSI 52BF
1 x Close before excitation failure	ANSI 48
1 x Phase sequence error	ANSI 47
1 x De-load error	ANSI 34
1 x Crank failure	ANSI 48
1 x Running feedback error	ANSI 34
1 x MPU wire break	
1 x Start failure	ANSI 48
1 x Hz/V failure	ANSI 53
1 x Stop failure	ANSI 48
1 x Stop coil, wire break alarm	ANSI 5
1 x Engine heater	ANSI 26
2 x Max. ventilation/radiator fan	
1 x Not in Auto	ANSI 34
1 x Fuel fill check	
1 x Vector jump	ANSI 78
1 x df/dt (ROCOF)	ANSI 81R
2 x Under-voltage and reactive power, U and Q	
1 x Positive sequence (mains) voltage low	ANSI 27
2 x Directional over-current	ANSI 67
1 x Negative sequence voltage high	ANSI 47
1 x Negative sequence current high	ANSI 46
1 x Zero sequence voltage high	ANSI 59G
1 x Zero sequence current high	ANSI 50G
1 x Power-dependent reactive power	ANSI 40
1 x IEC/IEEE inverse time over-current	ANSI 51

Wiring and dimensions

Typical wiring

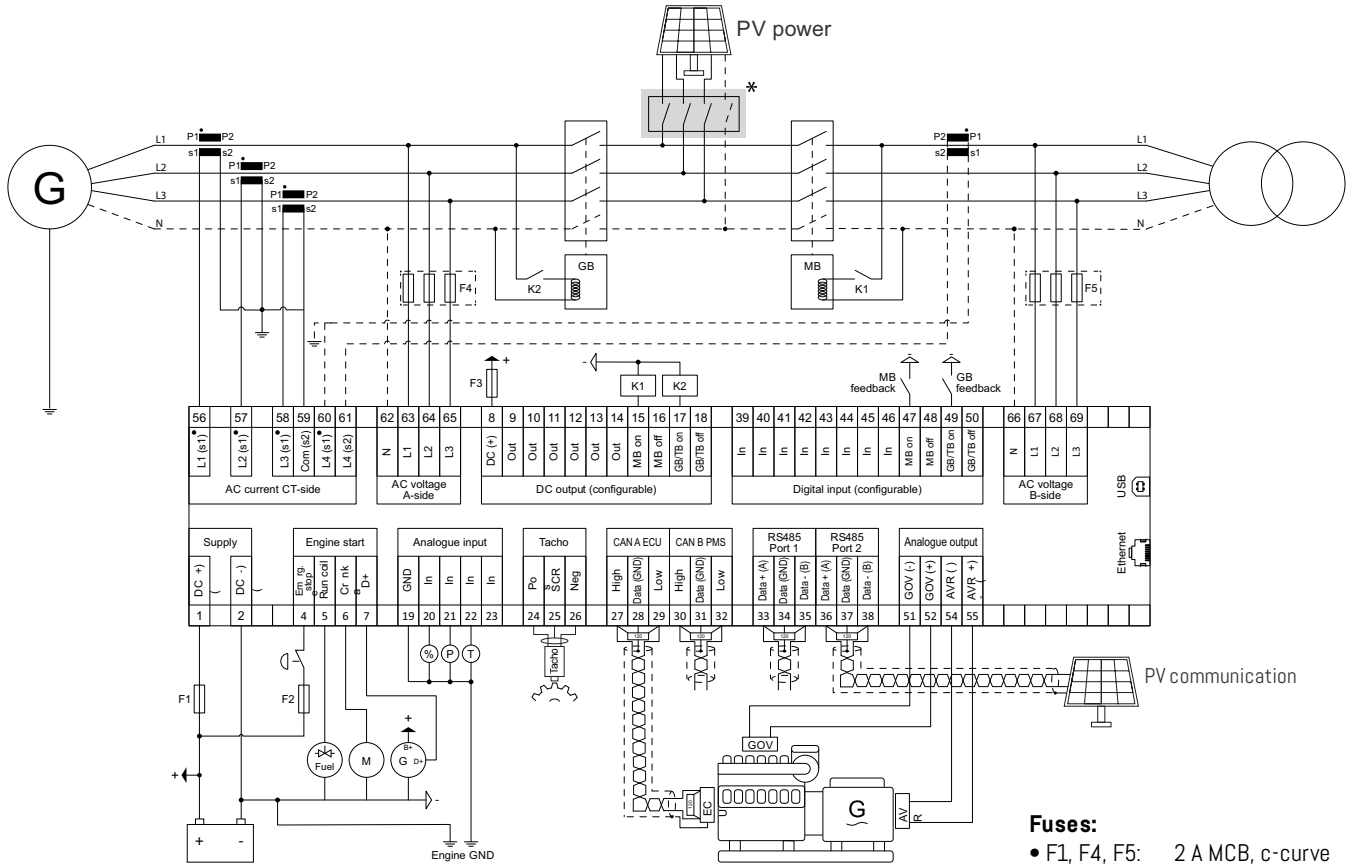

* Optional PV breaker

Fuses:

- F1, F4, F5: 2 A MCB, c-curve
- F2: 6 A MCB, c-curve
- F3: 4 A MCB, b-curve

Application examples

Application with PV inverters and a single generator

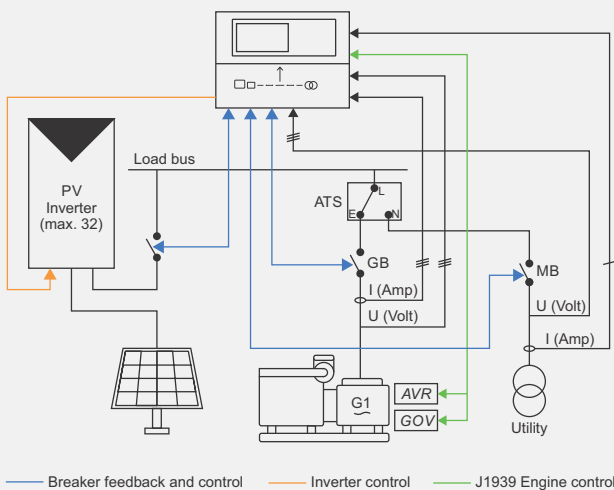

Full hybrid controller functions

Application with PV inverters and non-synchronising gensets

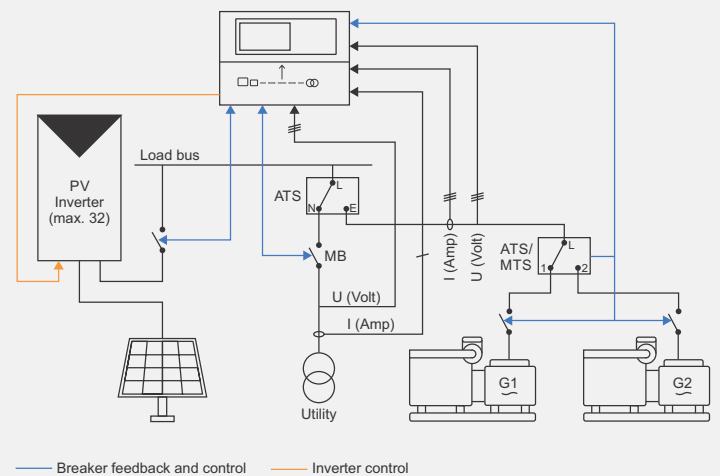

Full hybrid controller functions

fmtelectric ats system

AUTOMATIC TRANSFER SWITCHES

An ATS is a device that interfaces with a generator and the electrical system. It monitors the utility power and signals of generator to start if the utility power goes out of specifications or drops out entirely. Backup power is now fed to the main utility panel or an emergency panel via the ATS. Are sized based on the power requirements of the connected devices and the type of power sources involved. Some ATS units include monitoring features, allowing users to track power status, load levels and other relevant data. All FMT Group generators has the ATS system.

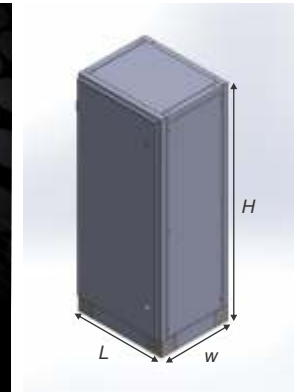
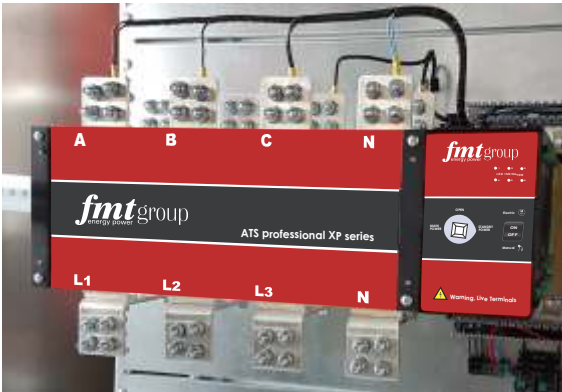

VOLTAGE	MODEL CONFIGURATION*	ATS PANEL MODEL	CAPACITY AMPS	Dimension (mm) W x L x H
6.3kV	3P5-V6.3KV-DEIF150E	NOT INCLUDED	-	-

*model configuration explanation

3P5-V400-DEIF420

Voltage 5-50Hz / 6-60Hz no. of phase 3P -threephase / 1P -monophase	AMF/Synchronize Control Unit
---	------------------------------

PRO-ACB Series
AIR CIRCUIT BREAKER

FMT PRO-ACB Series intelligent type universal circuit breaker is suitable for AC50HZ, rated voltage up to 660V(690) and below, rated current 400A-6300A of the distribution network used to distribute power and protect circuits and power supply equipment against overload, under-voltage, short circuit, single-phase ground fault. Circuit breaker protection with intelligent, selective protection of precision, improve the reliability of power supply, avoid unnecessary power outages. At the same time with an open communication interface for four remote, meet the requirements of the system centers and automation systems. The circuit breaker at an altitude of 2000 meters pulse pressure 8000V (different altitude correction according to the standard, no more than 12000V). The circuit breaker without in Intelligent Release and sensor can be used for isolation, mask as Circuit Breaker meets the requirement specified in GB14048.2 "low-voltage switchgear and control equipment low-voltage circuit breakers" and IEC947-2 "low-voltage switchgear and control equipment circuit breaker".



Producing with CE, ISO 45001-2018, ISO 8528-1, ISO 8528-5, ISO 8528-9, ISO 8528-10, ISO 8528-13, ISO 9001, ISO 9227, ISO 10002-2018, ISO 14001-2015, ISO 14040, ISO 31000-2018, ISO 50001-2018, SA 8000-2014 standards.

note:

- o All information given in this data sheet is intended for guidance only
- o FMT Group reserves the right to make change in any details without prior notice
- o The present documents will not be part of any sales contract



fmt group

energy power

ALBANIA (factory headquarter)

Address: "Rruga e Aeroportit SH60",
2km from Tirana International Airport,
Rinas - Fushe Kruje

mob: +355 69 70 66 835

e-mail: info@fmtgroup.al

KOSOVO

Address: Magjistratja Prishtine - Ferizaj, Km5
Cagllavice - Prishtine

MONTENEGRO

Address: Tuzi BB - Podgorice

TURKEY

Address: Eski Londra Asfaltlı Caddesi No:41-43A
Güngören / İstanbul

mob: +90 555 006 22 36

e-mail: sale6@fmtgroup.al



WE HAVE THE POWER



For more information please visit our websites

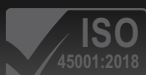
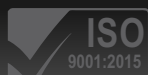

www.fmtgroup.al

www.fmtengine.com